

SCUDO



TECHNICAL SPECIFICATIONS AND EQUIPMENT

Trim levels and options may vary in response to specific legal or market requirements. The information in this publication is purely indicative. Fiat Professional reserves the right to make any changes to the models described in this publication at any time for technical or market reasons.
Fiat Marketing 04.3.5536.08 - S - 08/2009 Printed in Italy - Tipostampa (TO)
Publication printed on chlorine-free paper.

www.fiatprofessional.com



TECHNICAL SPECIFICATIONS.

SCUDO VAN - COMBI

Engine	90 Multijet			120 Multijet			140 Multijet Power						
No. of cylinders, arrangement	4, in line			4, in line			4, in line						
Position	transversely mounted at front			transversely mounted at front			transversely mounted at front						
Bore x stroke (mm)	75 x 88.3			85 x 88			85 x 88						
Displacement (cc)	1560			1997			1997						
Ecology level	Euro 4			Euro 4			Euro 4 DPF						
Emission control	2 oxidising catalysts + electrical EGR valve, EOBD			2 oxidising catalysts + electrical EGR valve, EOBD with or without particulate filter (DPF)			2 oxidising catalysts + electrical EGR valve, EOBD with particulate filter (DPF)						
Compression ratio	18.0 : 1			17.5 : 1			17.5 : 1						
Max. power output: kW-EC (bhp-EC) at rpm	66 (90) 4000			88 (120) 4000			100 (136) 4000						
Peak torque: Nm-EC (kgm-EC) at rpm	180 (18.3) 17500			300 (30.6) 2000			320 (32.6) 2000						
Timing system (control)	2 OHC's (toothed belt)			2 OHC's (toothed belt)			2 OHC's (toothed belt)						
Fuel feed	Electronically controlled 'Common rail' Multijet direct injection with supercharger and intercooler			Electronically controlled 'Common Rail' Multijet direct injection, variable geometry turbo and intercooler			Electronically controlled 'Common Rail' Multijet direct injection, variable geometry turbo and intercooler						
No. of valves	16			16			16						
Transmission													
Drive	front			front			front						
Clutch	self-adjusting single plate and hydraulic release system			self-adjusting single plate and hydraulic release system			self-adjusting single plate and hydraulic release system						
Gearbox, no. of speeds	5 + reverse			6 + reverse			6 + reverse						
Steering system													
Type	rack type with hydraulic power steering			rack type with electrohydraulic power steering			rack type with electrohydraulic power steering						
Steering diameter (kerb to kerb)	Short wheelbase m 12.2 - Long wheelbase m 12.6			Short wheelbase m 12.2 - Long wheelbase m 12.6			Short wheelbase m 12.2 - Long wheelbase m 12.6						
Brakes - D (disk)													
Front: Ø mm (ventilated disks)	with ABS D 280			with ABS D 304			with ABS D 304						
Rear: Ø mm	D 290			D 290			D 290						
Suspension system													
Front	independent wheel McPherson system, with lower wishbones and stabiliser bar												
Rear	torsion beam with coil springs, Panhard bar and slanted hydraulic shock-absorbers												
Wheels													
Wheels	7 J 16"			7 J 16"			7 J 16"						
Tyres	215 / 60 R 16			215 / 60 R 16			215 / 60 R 16						
Performance													
Top speed ▲ (km / h)	145			160			170						
Acceleration (sec.):*	0 to 100 km / h kerb weight vehicle + driver 17.1			12.8			11.6						
0 to 100 km / h with medium load	21.1			15.4			13.8						
Fuel consumption (lit./100 km) ▲ EC Directive 2004/3													
urban cycle / extra-urban cycle / mixed cycle	Short wheelbase van			Long wheelbase van			Maxi van			Short wheelbase van		Long wheelbase van	
	8.4 / 6.6 / 7.2			8.4 / 6.6 / 7.2			8.6 / 6.8 / 7.5			9.1 / 6.3 / 7.2		9.2 / 6.4 / 7.4	
CO ₂ emissions (g / km)	191			191			198			194		196	
	5/6 seater Combi			8/9 seater Combi			5/6 seater Combi			8/9 seater Combi		5/6 seater Combi	
urban cycle / extra-urban cycle / mixed cycle	Short wheelbase		Long wheelbase		Short wheelbase		Long wheelbase		Short wheelbase		Long wheelbase		
	8.4 / 6.6 / 7.2		8.6 / 6.8 / 7.5		8.6 / 6.8 / 7.5		8.6 / 6.8 / 7.5		9.1 / 6.3 / 7.2		9.2 / 6.4 / 7.4		
CO ₂ emissions (g / km)	191		198		198		198		194		196		
	196		196		199		199		196		196		
Weights - Tank capacity													
Max. towable weight (braking) (kg)	1433 ÷ 1672 (2000**)			2000			1834 ÷ 2000						
Tank capacity (litres)	80			80			80						

▲ figures relating to vehicles type-approved as passenger cars * 1000 kg Van ** Combi



Fiat recommends SELENIA engine oil, PARAFU coolants, TUTELA functional fluids.

PANELLED AND GLAZED VAN.

GLAZED AND PANELLED LONG WHEELBASE VAN.

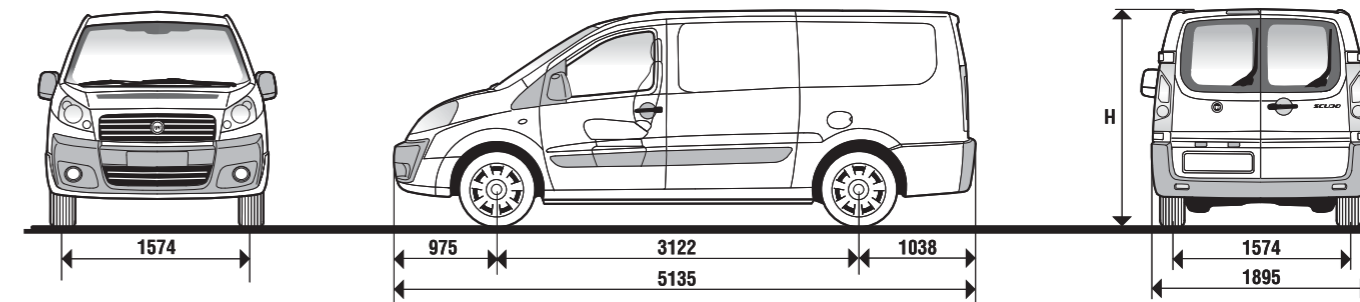
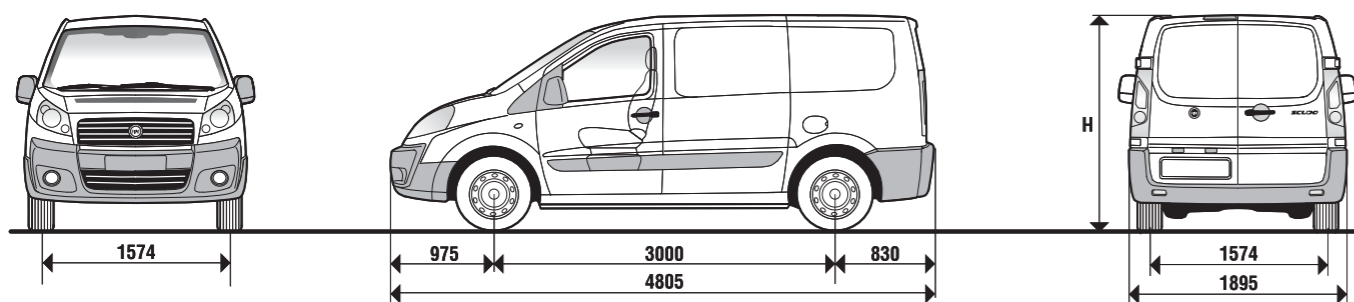

Dimensions (mm)	1000 kg Van		1200 kg Van	
Wheelbase	3000		3000	
Maximum length	4805		4805	
Maximum width*	1895		1895	
Front track	1574		1574	
Rear track	1574		1574	
H Maximum height (unladen)	1942 - 1894 (with air suspension)		1942 - 1894 (with air suspension)	
Front overhang	975		975	
Rear overhang	830		830	
Rear door				
Width	1237		1237	
Height	1272		1272	
Side door				
Width	924		924	
Height	1293		1293	
Loading compartment				
Maximum length	2254		2254	
Maximum width	1600		1600	
Width between wheelarches	1245		1245	
Maximum height	1449		1449	
Height of rear door loading threshold (unladen)	562 ÷ 604 (490 ÷ 499 with air suspension)		562 ÷ 604 (490 ÷ 499 with air suspension)	

Dimensions (mm)	1200 kg Van	
Wheelbase	3122	
Maximum length	5135	
Maximum width*	1895	
Front track	1574	
Rear track	1574	
H Maximum height (unladen)	1942 - 1894 (with air suspension)	
Front overhang	975	
Rear overhang	1038	
Rear door		
Width	1237	
Height	1272	
Side door		
Width	924	
Height	1293	
Loading compartment		
Maximum length	2584	
Maximum width	1600	
Width between wheelarches	1245	
Maximum height	1449	
Height of rear door loading threshold (unladen)	562 ÷ 604 (490 ÷ 499 with air suspension)	

5 m³ volume	1000 kg Van				1200 kg Van			
Engines	90 Multijet	120 Multijet	140 Multijet Power	120 Multijet DPF	90 Multijet	120 Multijet	140 Multijet Power	120 Multijet DPF
Vehicle weight▲ (unladen) (kg)	1661	1702	1717	1717	1661	1702	1717	1717
Payload including driver (kg)	1000	1000	1000	1000	1200	1200	1200	1200
GVW (kg)	2661	2702	2717	2717	2861	2902	2917	2917
Top speed (km / h)	145	160	170	170	145	160	170	170

6 m³ volume	1200 kg Van			
Engines	90 Multijet	120 Multijet	140 Multijet Power	120 Multijet DPF
Vehicle weight▲ (unladen) (kg)	1660	1732	1746	1746
Payload including driver (kg)	1200	1200	1200	1200
GVW (kg)	2860	2932	2946	2946
Top speed (km / h)	145	160	170	170

* Wing mirrors excluded
 ▲ 2-seater Van, ready for the road, with fuel, oil, water, spare wheel, tools and accessories

* Wing mirrors excluded
 ▲ 2-seater Van, ready for the road, with fuel, oil, water, spare wheel, tools and accessories

MAXI VAN.

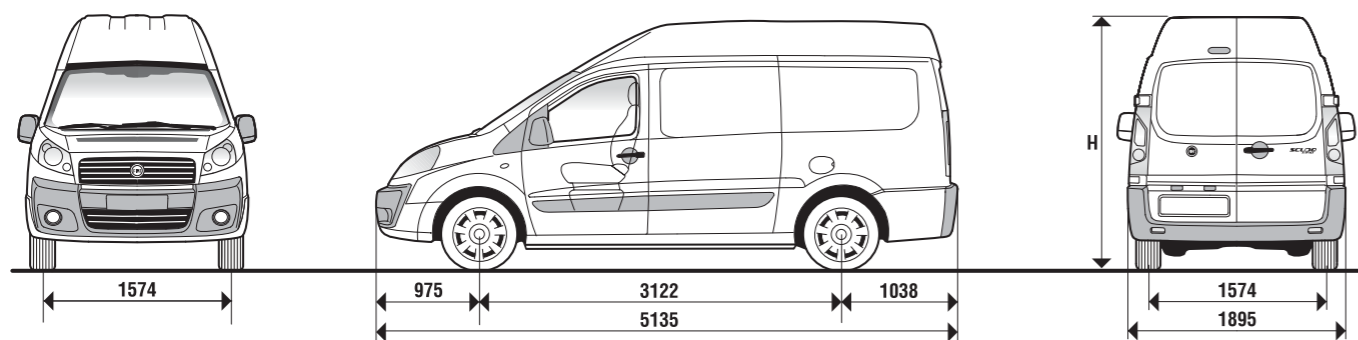

Dimensions (mm)		1200 kg Maxi Van	
Wheelbase		3122	
Maximum length		5135	
Maximum width*		1895	
Front track		1574	
Rear track		1574	
H Maximum height (unladen)		2276 - 2204 (with air suspension)	
Front overhang		975	
Rear overhang		1038	
Rear door			
Width		1237	
Height		1630	
Side door			
Width		924	
Height		1293	
Loading compartment			
Maximum length		2584	
Maximum width		1600	
Width between wheelarches		1245	
Maximum height		1750	
Height of rear door loading threshold (unladen)		562 ÷ 604 (490 ÷ 499 with air suspension)	

7 m³ volume		1200 kg Maxi Van		
Engines	90 Multijet	120 Multijet Power	120 Multijet DPF	
Vehicle weight▲ (unladen) (kg)	1700	1763	1778	
Payload including driver (kg)	1200	1200	1200	
GVW (kg)	2900	2963	2938	
Top speed (km / h)	145	160	160	

* Wing mirrors excluded
 ▲ 2-seater Van, ready for the road, with fuel, oil, water, spare wheel, tools and accessories

PLATFORM CAB.

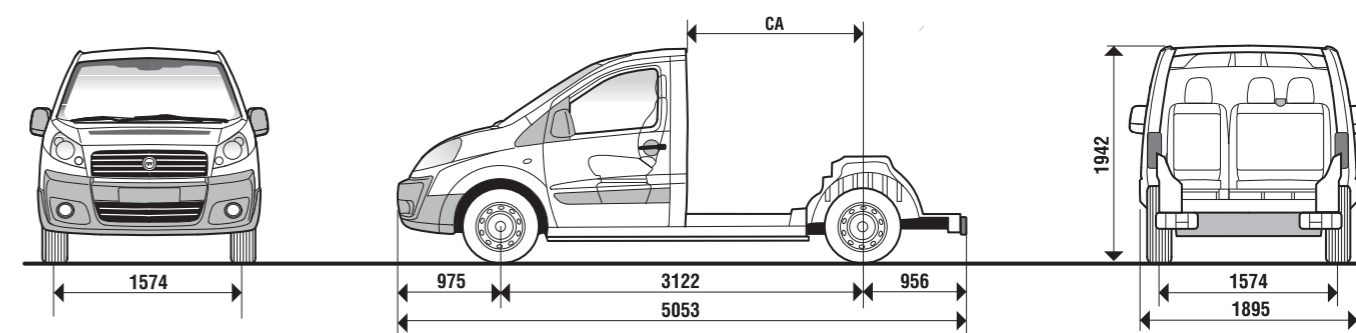

Dimensions (mm)		Platform cab.	
Wheelbase		3122	
Maximum length		5053	
Maximum width*		1895	
Front track		1574	
Rear track		1574	
Maximum height (unladen)		1942	
Front overhang		975	
Rear overhang		956	
CA Back of cab to rear axle		1473	

		Platform cab.		
Engines	90 Multijet	120 Multijet	120 Multijet DPF	
Unladen weight (kg)	1463	1553	1568	
GVW (kg)	3000	3000	3000	
Max. admissible load on front axle (kg)	1400	1400	1400	
Max. admissible load on rear axle (kg)	1700	1700	1700	

* Wing mirrors excluded

5/6 SEATER COMBI GLAZED, PARTLY GLAZED AND WITH N1 CLASS BULKHEAD. 5/6 SEATER PANORAMA.

5/6 SEATER COMBI WITH LONG WHEELBASE GLAZED, PARTLY GLAZED AND WITH N1 CLASS BULKHEAD. 5/6 SEATER PANORAMA WITH LONG WHEELBASE.

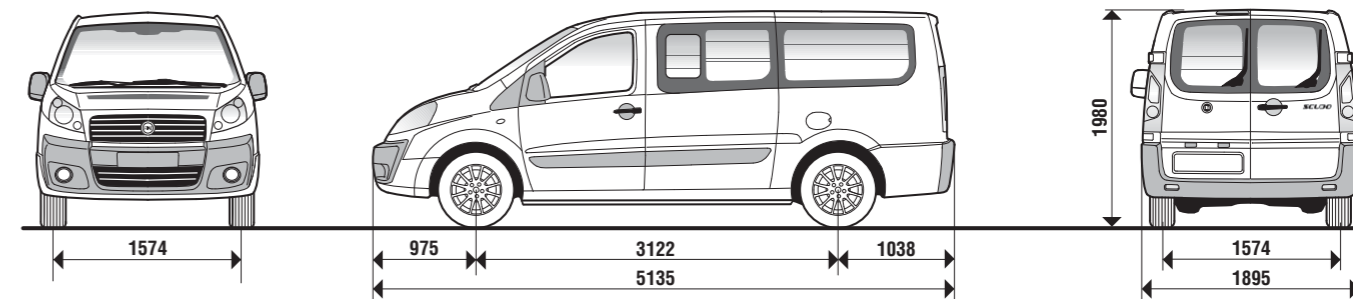
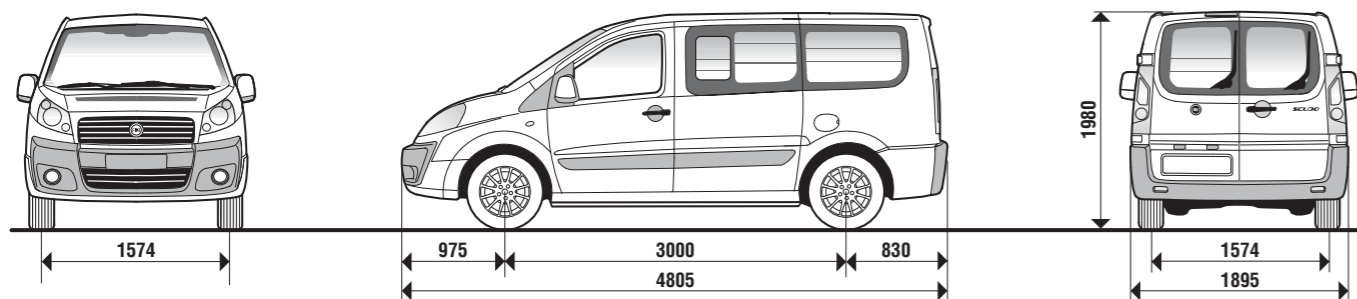

Dimensions (mm)		5/6 seater Combi and Panorama	
Wheelbase		3000	
Maximum length		4805	
Maximum width*		1895	
Front track		1574	
Rear track		1574	
Maximum height (unladen)		1980	
Front overhang		975	
Rear overhang		830	
Rear door			
Width		1237	
Height		1272	
Side door			
Width		924	
Height		1203	
Loading compartment			
Maximum length		1230 (short wheelbase) - 1555 (long wheelbase)	
Maximum width (Combi standard)		1600 (short wheelbase) - 1600 (long wheelbase)	
Maximum width (Combi Panorama)		1180 (short wheelbase) - 1180 (long wheelbase)	
Maximum height		1260 (short wheelbase) - 1260 (long wheelbase)	

Dimensions (mm)		5/6 seater Combi and Panorama with long wheelbase	
Wheelbase		3122	
Maximum length		5135	
Maximum width*		1895	
Front track		1574	
Rear track		1574	
Maximum height (unladen)		1980	
Front overhang		975	
Rear overhang		1038	
Rear door			
Width		1237	
Height		1272	
Side door			
Width		924	
Height		1203	
Loading compartment			
Maximum length		1230 (short wheelbase) - 1555 (long wheelbase)	
Maximum width (Combi standard)		1600 (short wheelbase) - 1600 (long wheelbase)	
Maximum width (Combi Panorama)		1180 (short wheelbase) - 1180 (long wheelbase)	
Maximum height		1260 (short wheelbase) - 1260 (long wheelbase)	

5/6 seater Combi and Panorama				
Engines	90 Multijet	120 Multijet	140 Multijet Power	120 Multijet DPF
Vehicle weight▲ (unladen) (kg)	1733 - 1745 (6 seats)	1809 - 1821 (6 seats)	1824 - 1836 (6 seats)	1824 - 1836 (6 seats)
Payload including driver (kg)	950 (5 seats + 610) 938 (6 seats + 530)	950 (5 seats + 610) 938 (6 seats + 530)	950 (5 seats + 610) 938 (6 seats + 530)	950 (5 seats + 610) 938 (6 seats + 530)
GVW (kg)	2683	2759	2774	2774
Top speed (km / h)	145	160	170	170

5/6 seater Combi and Panorama with long wheelbase				
Engines	90 Multijet**	120 Multijet	140 Multijet Power	120 Multijet DPF
Vehicle weight▲ (unladen) (kg)	1764 - 1776 (6 seats)	1841 - 1853 (6 seats)	1855 - 1867 (6 seats)	1855 - 1867 (6 seats)
Payload including driver (kg)	950 (5 seats + 610) 938 (6 seats + 530)	950 (5 seats + 610) 938 (6 seats + 530)	950 (5 seats + 610) 938 (6 seats + 530)	950 (5 seats + 610) 938 (6 seats + 530)
GVW (kg)	2714	2791	2805	2805
Top speed (km / h)	145	160	170	170

Combi with N1Class bulkhead				
Engines	90 Multijet	120 Multijet	140 Multijet Power	120 Multijet DPF
Vehicle weight▲ (unladen) (kg)	1745 - 1757	1821 - 1833	1836 - 1848	1836 - 1848
Payload including driver (kg)	920 (5 seats + 580) 908 (6 seats + 500)	929 (5 seats + 589) 917 (6 seats + 509)	929 (5 seats + 589) 917 (6 seats + 509)	929 (5 seats + 589) 917 (6 seats + 509)
GVW (kg)	2665	2750	2765	2765
Top speed (km / h)	145	160	170	170

Long wheelbase Combi with N1 Class bulkhead				
Engines	90 Multijet	120 Multijet	140 Multijet Power	120 Multijet DPF
Vehicle weight▲ (unladen) (kg)	1776 - 1788	1853 - 1865	1867 - 1879	1867 - 1879
Payload including driver (kg)	904 (5 seats + 564) 892 (6 seats + 484)	907 (5 seats + 567) 895 (6 seats + 487)	908 (5 seats + 568) 896 (6 seats + 488)	908 (5 seats + 568) 896 (6 seats + 488)
GVW (kg)	2680	2760	2775	2775
Top speed (km / h)	145	160	170	170

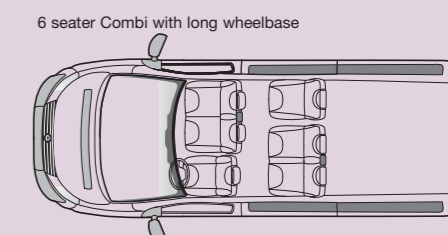
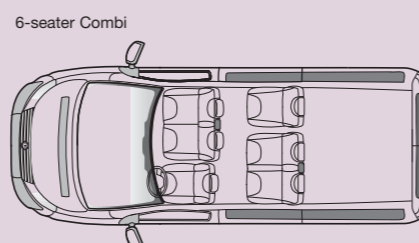

* Wing mirrors excluded
▲ Ready for the road, with water, fuel, oil, spare wheel, tools and accessories

* Wing mirrors excluded
▲ 2-seater Van, ready for the road, with fuel, oil, water, spare wheel, tools and accessories
** Not available in Panorama Family and Executive versions

8/9 SEATER COMBI 8/9 SEATER PANORAMA*

8/9 SEATER COMBI WITH LONG WHEELBASE. 8/9 SEATER PANORAMA WITH LONG WHEELBASE*

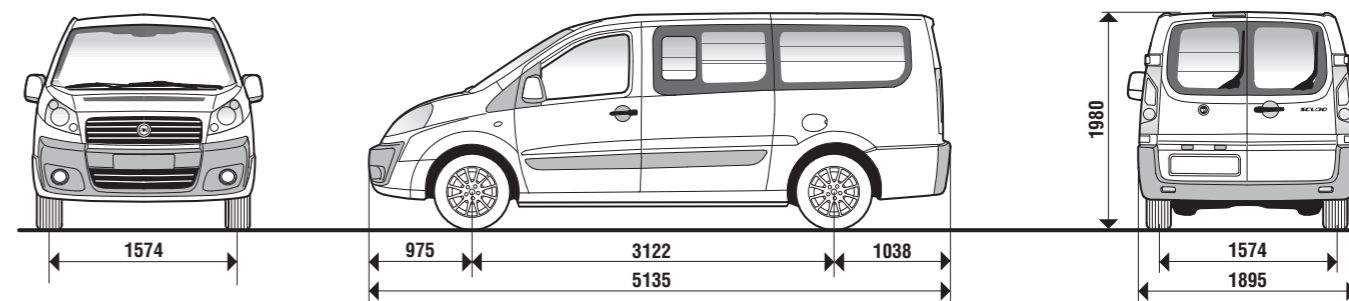
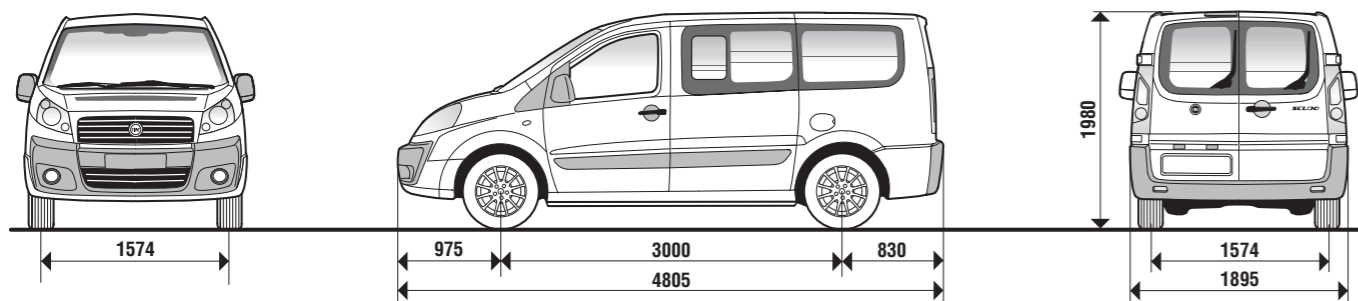

Dimensions (mm)		8/9 seater Combi and Panorama	
Wheelbase		3000	
Maximum length		4805	
Maximum width*		1895	
Front track		1574	
Rear track		1574	
Maximum height (unladen)		1980	
Front overhang		975	
Rear overhang		830	
Rear door			
Width		1237	
Height		1272	
Side door			
Width		924	
Height		1203	

Dimensions (mm)		8/9 seater Combi and Panorama with long	
Wheelbase		3122	
Maximum length		5135	
Maximum width*		1895	
Front track		1574	
Rear track		1574	
Maximum height (unladen)		1980	
Front overhang		975	
Rear overhang		1038	
Rear door			
Width		1237	
Height		1272	
Side door			
Width		924	
Height		1203	

8/9 seater Combi and Panorama				
Engines	90 Multijet	120 Multijet	140 Multijet Power	120 Multijet DPF
Vehicle weight▲ (unladen) (kg)	1811 - 1822 (9 seats)	1887 - 1898 (9 seats)	1902 - 1913 (9 seats)	1902 - 1913 (9 seats)
Payload including driver (kg)	872 (8 seats + 328) 861 (9 seats + 249)	872 (8 seats + 328) 861 (9 seats + 249)	872 (8 seats + 328) 861 (9 seats + 249)	872 (8 seats + 328) 861 (9 seats + 249)
GVW (kg)	2683	2759	2774	2774
Top speed (km / h)	145	160	170	170

8/9 seater Combi and Panorama with long wheelbase				
Engines	90 Multijet	120 Multijet	140 Multijet Power	120 Multijet DPF
Vehicle weight▲ (unladen) (kg)	1842 - 1853 (9 seats)	1919 - 1930 (9 seats)	1933 - 1944 (9 seats)	1933 - 1944 (9 seats)
Payload including driver (kg)	872 (8 seats + 328) 861 (9 seats + 249)	872 (8 seats + 328) 861 (9 seats + 249)	872 (8 seats + 328) 861 (9 seats + 249)	872 (8 seats + 328) 861 (9 seats + 249)
GVW (kg)	2714	2791	2805	2805
Top speed (km / h)	145	160	170	170

8/9 seater Combi and Panorama with long wheelbase and higher payload				
Engines	90 Multijet	120 Multijet	140 Multijet Power	120 Multijet DPF
Vehicle weight▲ (unladen) (kg)	1857 - 1868 (9 seats)	1934 - 1945 (9 seats)	1948 - 1959 (9 seats)	1948 - 1959 (9 seats)
Payload including driver (kg)	996 (8 seats + 452) 984 (9 seats + 372)	999 (8 seats + 455) 987 (9 seats + 375)	999 (8 seats + 455) 987 (9 seats + 375)	999 (8 seats + 455) 987 (9 seats + 375)
GVW (kg)	2852	2932	2946	2946
Top speed (km / h)	145	160	170	170

9-seater Combi

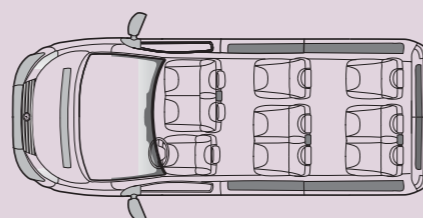

9-seater Combi with long wheelbase

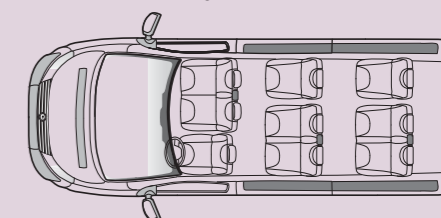

▼ 5/6 seater version with 3rd seat row (option)

* Wing mirrors excluded
▲ Ready for the road, with water, fuel, oil, spare wheel, tools and accessories

▼ 5/6 seater version with 3rd seat row (option)

* Wing mirrors excluded
▲ Ready for the road, with water, fuel, oil, spare wheel, tools and accessories

STANDARD EQUIPMENT AND OPTIONS.

SCUDO

	Van and glazed Comfort version	Van and glazed SX version	Platform cab	Combi and partly glazed	Panorama Family	Panorama Executive
Exterior						
Fuel tank plug with lock						
Tinted windows						
Heated electrical wing mirrors + power windows with antipinching function	041	•	•	•	•	–
Heated, electrically adjustable and folding wing mirrors + power windows with antipinching function	441	•	•	•	•	•
Privacy windows on 2 nd and 3 rd rows + backlight	070	•▲	•▲	–	•	•
Fog lights	097	•	•	•	•	•
16" alloy wheels	108	–	–	–	•	•
Tailgate with heated backlight with wiper	148	•/– (Maxi)	•/– (Maxi)	–	•	•
Metallic paint	210	•	•	•	•	•
Tinted windshield	253	•	•	•	•	•
Hinged rear doors with heated backlight with wiper	372	•	•	–	•	•
Easy Drive Pack: radio and CD player with controls on the steering wheel, parking sensors, painted electric folding door mirrors, cruise control	5WX	•	•	–	–	–
Integral pack: painted bumpers, painted side mouldings, grey exterior handles, painted and electrically folding wing mirrors, fog lights, hub caps, painted rear hinge covers	457	•	•	•	•	•
Look pack: partly painted bumpers, fog lights, hub caps, painted rear hinge covers	909	•	•	•	•	•
Easy Load Pack: air suspension with adjustable loading threshold, parking sensors, heated, electrically adjustable and folding wing mirrors + power windows with antipinching function	4QI	•	•	•	–	–
Panelled 2 nd side sliding door	513	•	•	–	–	–
Hinged glazed rear doors without heated backlight with wiper	519	•▲	•▲	–	–	–
Glazed sliding side door (excl. Maxi)	520	•▲	•▲	–	–	–
2 glazed sliding side doors (excl. Maxi)	522	•	•	–	•	•
Fixed windows on 2 nd row (with glazed side doors)	643	•	•	–	•	•
Opening windows on 2 nd row (with glazed side doors)	644	•	•	–	•	•
Rear light clusters (mounted on service cross-beam)		–	–	–	–	–

▲ Glazed van

Interior

Steering wheel adjustable for height and distance						
Oddments tray in upper part of cab (Capucine)						
Driver's seat adjustable for height without armrest		–	–	–	–	–
2 nd row seats removable and double folding		–	–	–	–	–
2 nd row seats with individually folding backs, removable and double folding	4HF	–	–	–	•	•
PVC lined floor						
Carpet lined floor		–	–	–	–	–
Multifunctional facia with open compartments, lockable glove box, storage cabinet and cup holder doors						
Cab door panels with opening controls and electrical window winders						
Driver protection ladder	194	•▲	•▲	–	–	–
Luggage cover + short hat rack	131	–	–	–	•	•
Fixed panelled bulkhead	149	•▲	•▲	–	–	–
Double passenger seat without front passenger airbag	186	•	•	•	•	•
Fixed glazed bulkhead (with central tunnel)	199	•	•	–	–	–
Double passenger seat with pretensioned belts, compatible with passenger airbag	293	•	•	•	•	•
3 rd row seats (individual seats) (bench + individual seat) removable and double folding	4MK	–	–	–	•	•
3 rd row seats reclining, removable and double folding	40H	–	–	–	•	•
Heated driver's seat and individual passenger seat	452	•	•	•	•	•
Heated front seats (driver and 2 passengers)	453	•	•	•	•	•
Cab Comfort kit: 2 facia-mounted pull-out cup holders, cigarette lighter, requires electrical wing mirrors or electrically folding wing mirrors	4B0	•	•	•	•	•
Comfort pack: heated front seats with side bag (452 + 505)	4RK	•	•	•	•	•

▲ Glazed van

Interior

	Van and glazed Comfort version	Van and glazed SX version	Platform cab	Combi and partly glazed	Panorama Family	Panorama Executive
Driver's seat with height and lumbar adjustment and armrest, also for passenger seat	627	•	•	•	•	•
Driver seat and double passenger seat covered with imitation leather	727	•	•	–	–	•
Functional / Electrical						
Power steering						
Headlamp adjuster						
Centralised locking with 3-button remote						
Third stop light			–	–	–	–
Ceiling light in loading compartment			–	–	–	–
Ceiling light fixture in passenger compartment and ceiling cover		–	–	–	–	–
Air diffuser for rear seats		–	–	–	–	–
Manual climate control + heated electrical wing mirrors, power windows with antipinching function	025	•	•	•	•	•
Automatic dual zone climate control with tinted windshield	140	–	–	–	•	•
Rain and twilight sensors + multipurpose display on facia, body computer	051	•	•	•	•	•
Self-levelling air suspension	062	•	•	•	•	•
Air suspension with adjustable loading threshold	555	•	•	•	•	•
Air-conditioning + additional Webasto heater at rear	204	–	–	–	–/• (8-9 seats)	•
Additional Webasto heater	205	•	•	•	•	•
Volumetric antitheft and deadlocks	224	•	•	•	•	•
Load space mid-height cover kit + 12 V power socket	324	–	–	–	–	–
Luggage retaining nets	381	–	–	–	•	•
Cruise Control	416	•	•	•	•	•
Parking sensors	508	•	•	•	•	•
Higher payload + alloy wheels and 215/60 R 16 C tyres (8/9 seater long wheelbase Combi versions)	943	–	–	–	•	•
Technical box for bodybuilders	081	•	•	•	•	•
2.1 m conversion kit	036	–	–	•	–	–

Safety

Head restraints adjustable for height						
3-point seat belts with retractors on all seats						
ABS + EBD						
Driver airbag						
ESP	392	•	•	•	•	•
Passenger airbag + visor with mirror	502	•	•	•	•	•
Side bag	505	•	•	•	•	•
Window bag	614	–	–	–	•	•

Audio / Telematics

Car radio with CD player and steering-wheel mounted controls (4 speakers)	313	•	•	•	•	6 speakers	6 speakers
Radio with CD player, MP3, 4 speakers, steering wheel mounted controls, Bluetooth™ and USB BOX	41A	•	•	•	•	•	•
Charger on facia	563	•	•	•	•	•	•
Radio with CD player, Navigator by maps, integrated telephone (includes non-folding heated electrical wing mirrors, rain and twilight sensors, fog lights)	904	•	•	•	•	•	•

■ = Standard • = Option – = Not available

TECHNICAL GLOSSARY

Self-levelling suspension

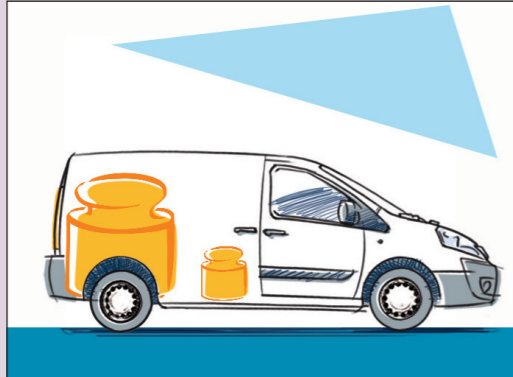

This suspension system keeps vehicle trim constant, regardless of the size and arrangement of the load, thus improving safety and driving comfort. It also lets you reduce by up to 5 cm the distance from the ground of the load space threshold.

Electrohydraulic power steering

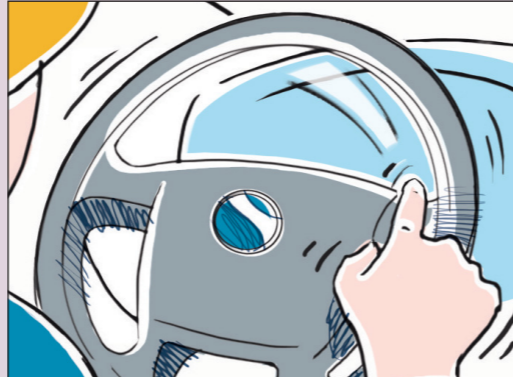

120 Multijet and 140 Multijet Power versions are equipped with electrohydraulic power steering, which reduces the force it takes to turn the steering-wheel when manoeuvring in tight corners and ensures maximum precision at high speeds. Power assistance is provided by means of an electric pump assembly controlled by vehicle speed and steering-wheel rotation speed (i.e., is independent of engine speed).

ESP – Electronic stability program

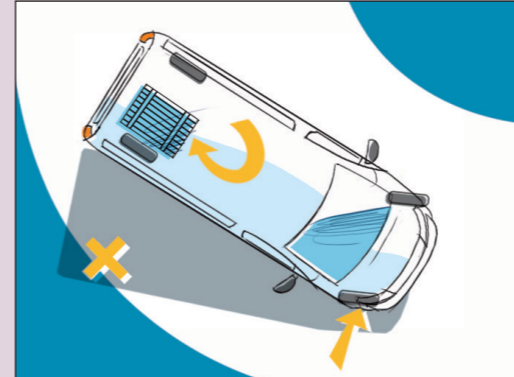

This system intervenes in emergency situations, such as, for example, sudden swerving to avoid an obstacle. The system monitors parameters such as sideways acceleration, speed, grip and the angle of the steering wheel. It processes the data and, if necessary, acts on the engine torque and braking system to restore the vehicle to conditions of perfect stability.

EBD – Electronic brake force distribution

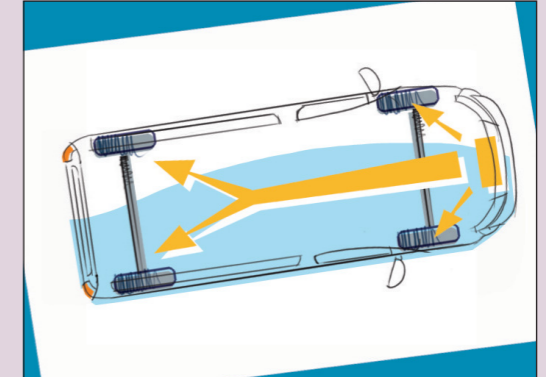

This electronic system splits the braking force between the front and rear axle, for greater braking efficiency in all driving situations.

Parking sensors



These sensors provide the driver with information about the distance between the vehicle and any obstacles behind it. The system is activated when reverse gear is engaged and uses 4 ultra-sound sensors. As the vehicle approaches an obstacle, an intermittent beep is heard. A continuous beep indicates that the minimum distance from the obstacle has been reached.

ASR – Anti-slip system

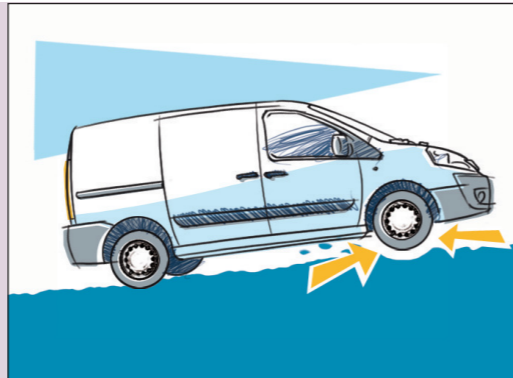

This system counteracts slipping effects on one or both driving wheels in poor grip conditions, by applying the brakes and at the same time temporarily reducing the power delivered by the engine.

Easy entry

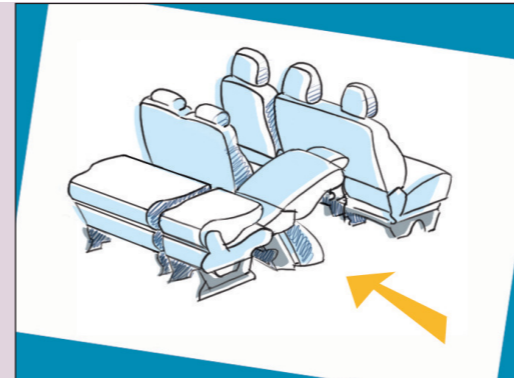

The right side seat of the second row is equipped with the easy entry function: it can be folded over individually to facilitate access to the third row.

Second seat row configurations

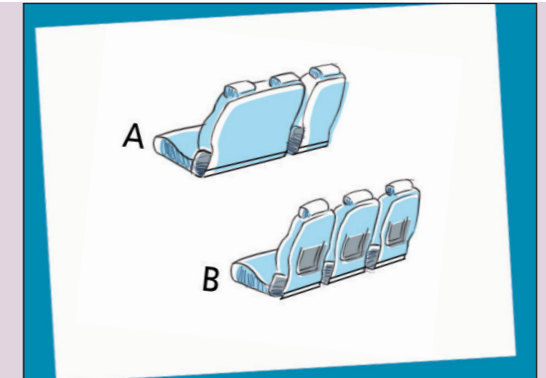

A) 2-seater bench with easy entry function. Double folding and removable seats. Standard on Combi versions.
B) 2-seater bench with equipped seatbacks, reclining, individually folding, double folding, removable seats. Easy entry. Standard on Panorama Family and Executive versions.

HBA – Emergency brake assist

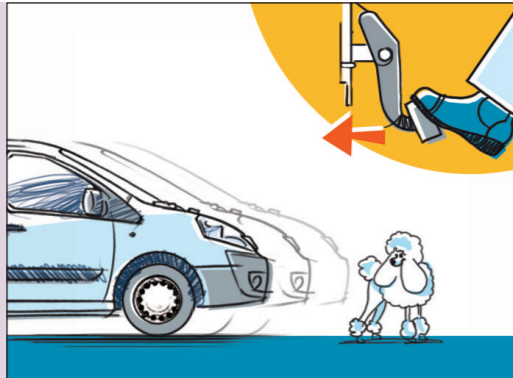

This system automatically increases the pressure in the braking circuit in emergency braking situations, by directly applying the servo-brake.

ABS – Anti-lock braking system

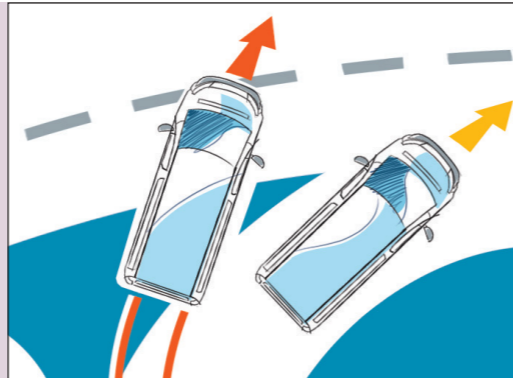

This system prevents one or more of the wheels from locking in an emergency braking situation, provides greater grip and therefore better road-holding.